

# SPECIFICATION

## TRACCESS 135 and 135/1

### TECHNICAL DATA

- Articulated boom (one element) + telescopic boom (main boom + extension) + jib
- 320° turret rotation on bearing turntable
- Individual hydraulic controls in basket
- Engine start and stop controls from basket
- Basket base in composite material with aluminium guardrails  
(1300 x 780 x 1100 mm - Traccess 135)  
(700 x 780 x 1100 mm - Traccess 135/1)
- Automatic hydraulically actioned basket levelling
- Basket load sensing device
- N° 4 hydraulic outriggers with ground pressure sensors
- 230V AC EC electrical socket in the basket
- Gradeability approximately 31%
- Drive speed max 1,5 Km /h
- Single cylinder 13 HP petrol engine (Traccess 135/1)  
Single cylinder 15 HP petrol engine (Traccess 135)
- Electro-hydraulic steering from the ground with an umbilical remote control system
- 230V 1,5 Kw auxiliary engine
- Hour meter
- Standard boom colours blue (RAL 5017) or white (RAL 9010)
- CE certified
- Remote spiral cable for traverse from ground

<b>PERFORMANCE TRACCESS</b>	<b>135/1</b>	<b>135 E</b>
Working height	13,3 m	13 m
Platform height	11,3 cm	11 m
Working outreach	7 m	6,5 m
Capacity	120 kg	200 kg
Basket dim.	700x780x1100xmm	1300x780x1100 mm
Closed dimensions (transit)	780x2000x3760 mm	780x2000x3760 mm
Unit weight	1450 kg	1600 kg



## TECHNICAL DETAILS

- 2 x Safety Harness hooking locations on the platform
- Emergency push button
- Emergency manual pump
- Outriggers/boom interlocking facility
- Manual emergency lowering valves
- Cylinders with safety non-return valves
- Intermittent buzzer for traverse and turnable rotation
- Active track braking system automatically applied in stationary mode
- Instructions & Maintenance Manual

### TRACCESS 135 E

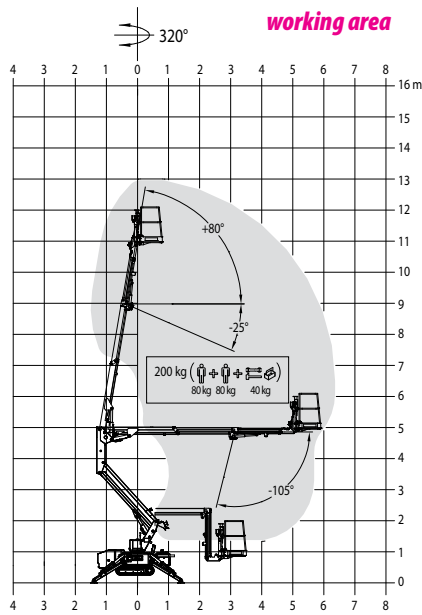

### platform dimensions

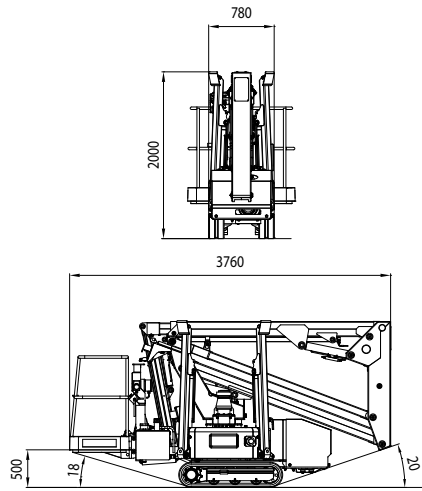

### TRACCESS 135/1

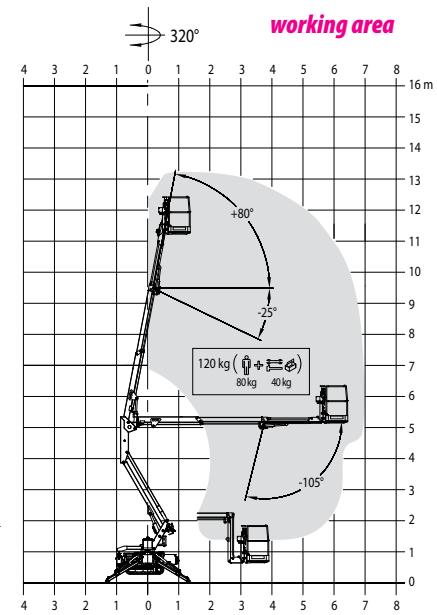

### stabilization

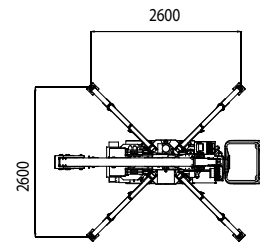
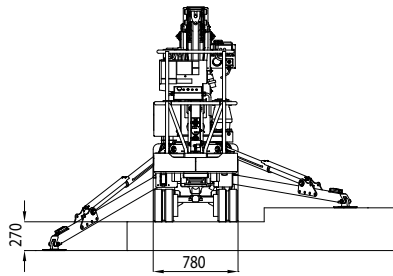
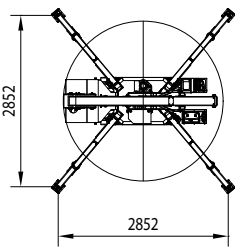

## KEY POINTS

Compact closed dimensions: 78 cm (width) x 200 cm (height)

Basket load sensing device

Clean top boom, internal mounted services

Individual hydraulic controls from basket

230 V 1,5 Kw auxiliary engine

Single cylinder 13 HP petrol engine (Traccess 135/1)  
Single cylinder 15 HP petrol engine (Traccess 135 E)

200 kg basket capacity throughout entire working area (135 E)  
120 kg basket capacity throughout entire working area (135/1)

CTE S.p.A. | [www.ctelift.com](http://www.ctelift.com)

Sales Office Dolo (Ve) - [dolo@ctelift.com](mailto:dolo@ctelift.com)  
ph. +39 041 51.00.130 - fax +39 041 41.38.44  
Headquarter Rovereto (Tn) - [info@ctelift.com](mailto:info@ctelift.com)  
ph. +39 0464 48.50.50 - fax +39 0464 48.50.99  
Milano Branch S. Giuliano Milanese (Mi) - [milano@ctelift.com](mailto:milano@ctelift.com)  
ph. +39 02 98.81.100 - fax +39 02 98.28.20.96  
Bertinoro Branch & Factory (FC) - [bertinoro@ctelift.com](mailto:bertinoro@ctelift.com)  
ph. +39 0543 44.88.30 - fax +39 0543 44.83.43

**TRACCESS**